

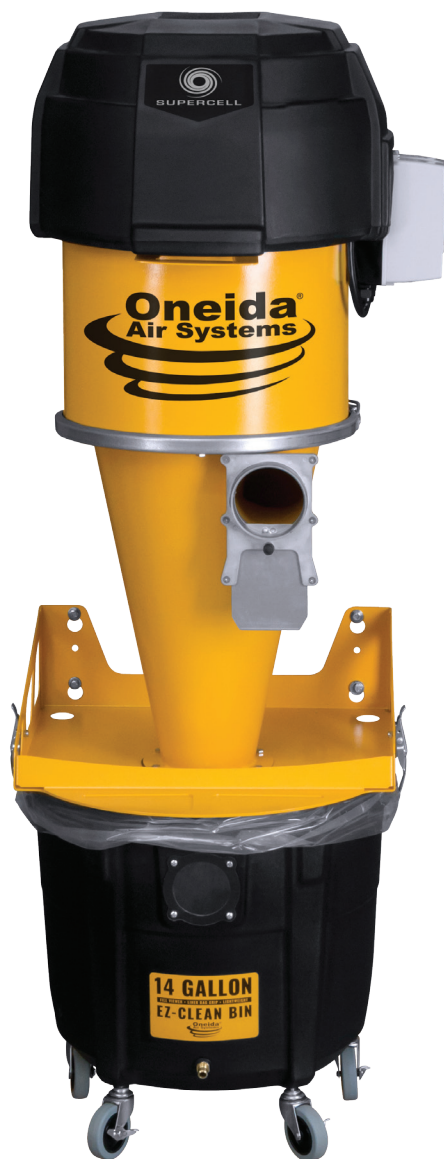

OWNER'S MANUAL



Supercell® Supercell® Turbo High-Pressure Dust Collector

14 Gallon

XSK000014

XSK414000

EXP-XSK000014

Patents: www.oneida-air.com/patents



Intertek



READ AND UNDERSTAND ALL INSTRUCTIONS AND WARNING LABELS BEFORE USING THE DUST COLLECTOR.

Table of Contents

System Start-Up Information.....	2
Supercell/Supercell Turbo System Specifications.....	6
System Dimensions.....	7
System Contents.....	8
Assembly Instructions.....	10
Maintenance.....	24
F.A.Q.	26
Troubleshooting.....	29
Recommended Accessories.....	31
Warranty Information.....	33

System Start-Up Information

Before Purchasing or installing a dust collection system the process owners/operators are cautioned to do so in accordance with prescribed Federal, State, Local, OSHA, NFPA, and any other applicable codes or regulations relating to the type of dust(s) you are collecting.

This manual contains specific precautionary statements relative to worker safety. Read thoroughly and comply as directed. The most up to date safety information can be found on our website: oneida-air.com/safety

WARNING

1. READ and understand ALL instructions and warning labels BEFORE using the dust collector.
2. REPLACE warning labels if they become obscured or removed.
3. ALWAYS follow all applicable federal, state, local, OSHA, NFPA, or authorities having jurisdiction codes and regulations when installing and operating this dust collector.
4. ENSURE that all users of this dust collector are informed of all warnings and precautions, safe use, and maintenance procedures.
5. FULL mental alertness is required. The machine is not intended for use by persons (including children) with reduced physical, sensory or mental capabilities, or lack of experience and knowledge.
6. DO NOT allow use by or near children.
7. DO NOT allow it to be used as a toy.
8. NEVER leave the dust collector running while unattended.
9. TURN OFF and UNPLUG the dust collector BEFORE walking away, servicing, or cleaning. Allow the fan blower motor to come to a COMPLETE STOP before walking away or performing any maintenance, service, cleaning, or adjustments. This eliminates the risk of injury from unintended startup or contact with live electrical components.
10. ENSURE that your dust collector is turned OFF and UNPLUGGED during installation. This eliminates the risk of injury from unintended startup or contact with live electrical components.
11. COMPLETELY INSTALL ductwork/flex hose before operating collector.
 - a. Seal ductwork with silicone sealant or duct tape if leaks are found.
 - b. Have dust drum in place and sealed.
 - c. NEVER operate without filter and cowling in place. This machine has high speed rotating elements than can cause severe injury.
12. ONLY use the dust collector for its intended purpose as described in this manual. DO NOT force it or an attachment to do a job for which it was not designed. Consult this owner's manual or reach out for recommended accessories.

System Start-Up Information (Continued)

13. ENSURE enough air volume is at the suction point to capture all the particulate generated.
14. NEVER make modifications without prior approval from Oneida Air Systems. Modifying the dust collector or using it differently than intended will void the warranty and may result in malfunction or mechanical failure that leads to serious personal injury or death! DO NOT allow use as a toy.
15. DO NOT locate or operate the system in moist, wet, poorly lit, or cluttered environments. Operating in these areas can create shock hazards, increase the risks of accidents and injury, and/or lower the operating lifespan of the dust collector.
16. DO NOT install in classified hazardous atmospheres without an enclosure rated for the application. System location must account for wind, seismic zone, and other load conditions. Codes may regulate acceptable locations for installing dust collectors. Consult with the appropriate authorities having jurisdiction to ensure compliance with all national and local codes regarding dust collector installation. Equipment must be anchored in a manner consistent with local code requirements. Anchors must be sufficient to support dead, live, seismic, and other anticipated loads. Consult a qualified engineer for final selection of anchorage.
17. ENSURE exhaust air is properly vented. It should NOT be vented into a wall, a ceiling, or a concealed space of a building. Personal injury, death, and/or property damage can result from material discharge during venting. The risk of personal injury and/or property damage can be minimized or avoided by locating vented equipment outside buildings and away from normally occupied areas. If exhaust air is vented outside, you must provide make up / return air. Flue gases (carbon monoxide) can be drawn into the shop from furnaces, water heaters, or other appliances.
18. INSPECT and MAINTAIN REGULARLY. Keep the dust collector in proper working order. A machine that isn't properly maintained, not working as it should, has been dropped, damaged, left outdoors, or dropped in water could malfunction leading to serious personal injury or death!
19. AVOID CORD DAMAGE. DO NOT pull or carry by cord. DO NOT use cord as handle. DO NOT unplug by pulling on cord. To unplug, grab the plug, NOT the cord. DO NOT close door on cord or pull cord around sharp edges or corners. DO NOT run dust collector over cord. DO NOT handle cord/plug with wet hands. Keep cord away from heated surfaces. If the supply cord is damaged, it must be replaced by the manufacturer, its service agent or similarly qualified persons in order to avoid a hazard.
20. ALWAYS check for damaged parts. A part that is damaged should be carefully checked to determine that it will operate properly and perform its intended function. Immediately repair or replace damaged or mis-adjusted parts before operating machine.
21. DO NOT put any object in openings. DO NOT use with any opening blocked. (Except when pulsing - See Maintenance Section for more information.)
22. ALWAYS wear a NIOSH approved respirator when emptying dust bins and during operation. Some dust created by power sanding, sawing, grinding, drilling, and other construction activities contains chemicals known to cause cancer, birth defects or other long-term respiratory damage.
23. ALWAYS keep hair, loose clothing, fingers, and all parts of body AWAY from openings and moving parts.
24. ALWAYS wear ANSI-approved safety glasses or a face shield when operating or observing machinery and when emptying dust bin.
25. ALWAYS wear hearing protection during extended periods of operation.

System Start-Up Information (Continued)

Process owners/operators retain all responsibility for the suitability of fire and explosion hazard mitigation, suppression, and isolation strategies and to follow all applicable federal, state, local, OSHA, NFPA, or authorities having jurisdiction codes and regulations when installing and operating this dust collector.

Improper operation of a dust control system may contribute to conditions in the work area or facility that could result in severe personal injury and product or property damage.

Oneida Air Systems assumes no responsibility or liability for the suitability of any fire and/or explosion mitigation strategy, or any items incorporated into a collector as part of an owner/operators hazard mitigation strategy.

FIRE HAZARDS

1. THIS UNIT IS NOT RATED FOR USE IN COMBUSTIBLE ENVIRONMENTS.
2. DO NOT operate the dust collector in areas where explosion risks are high. Areas of high risk include, but are not limited to, areas near pilot lights, open flames, or other ignition sources.
3. ONLY operate dust collector in locations that include a fire suppression system or have a fire extinguisher available nearby.
 - a. The ABC type (dry chemical) is generally a good choice for small wood shops.
 - b. Additional information on portable extinguishers can be found in NFPA 10 (Standard for Portable Fire Extinguishers).
4. DO NOT allow accumulation of layers of fine dust on horizontal surfaces. Especially overhead lights, electrical boxes and fuse panels which can ignite dust. Keep the floor around the system clean and free of scrap material, oil, grease.
5. ENSURE all equipment and ductwork is electrically grounded.
6. DO NOT use PVC drain pipe.
7. ALWAYS consult an electrician or qualified service personnel about wiring practices and electrical codes in your area. ONLY allow an electrician or qualified service personnel to do electrical installation or repair work.
8. ALWAYS disconnect power before accessing or exposing electrical equipment. Improper wiring can cause fire, electrocution, injury, or death.
9. DO NOT use to pick up anything that is burning or smoking, such as cigarettes, matches, or hot ashes.
10. DO NOT use to pick up liquids, flammable liquids, or combustible liquids, such as gasoline, or use in areas where they may be present.
11. DO NOT use excessively large wood waste bins. Wood dust mixtures are highly flammable and can be explosive

System Start-Up Information (Continued)

12. ALWAYS check your dust bin for smoldering materials before leaving the shop.
13. NEVER introduce sparks or sources of ignition into the dust collector. Sparks can be generated in several ways:
 - a. High speed sanders, abrasive planers, saws, and edgers may strike foreign material and create a red-hot metal fragment.
 - b. Knots in hardwood can create frictional sparks.
 - c. Trapped metal, when drawn into the dust collection system, can spark against ductwork.
 - d. Check wood stock for old nails and screws which can create red-hot metal fragments.
14. DO NOT overload woodworking equipment, especially sanders, as excessive frictional heat can spontaneously ignite dust. Sanders can produce concentrations of dust well into the combustible range.
15. ALWAYS check that all dust collection equipment is properly selected and sized for the intended use. Authorities with jurisdiction should be consulted before installing to verify local codes and installation procedures. In the absence of such codes, install collector according to the National Electric Code, NFPA No. 70-latest edition and NFPA 91, NFPA664 Code (NFPA 654 if combustible dust is present).

Customer Service Dept.

1-866-387-8822 • support@oneida-air.com

Supercell/Supercell Turbo System Specifications

OPERATION		
Maximum Suction Rating	97.8" WC	
MOTOR AND ELECTRICAL		
Motor Type	3x 1300W Modular Motors	4x 1300W Modular Motors
Horsepower	5HP Total	6.7 HP Total
Motor Speed	48,880 RPM	
Phase	1-Phase	
Voltage	208-230V	
Cycle	60HZ	
Listed FLA	18A	22A
On/Off Switch	Magnetic Starter with On-Off Switch and RF Remote	
Power Cord Length	9 feet	
Power Connector	NEMA 6-20	Bare Wiring: Two Hot Wires and a Ground
Recommended Circuit Size	20A	30A
Recommended Circuit Type	HACR	
Sound Emission	80 dBA @ 10 ft	85 dBA @ 10 ft
CARTRIDGE FILTER		
Filter Media Type	HEPA Grade ePTFE Media	
Filter Efficiency	E12	
Filter Surface Area	40 sq ft	
SYSTEM DIMENSIONS AND CONSTRUCTION		
Primary Build Materials	Cold Rolled Steel, Static Dissipative Polyethylene	
Inlet	4" O.D.	
Discharge to Drum	5" O.D.	
Overall Height	14 Gallon: 61"	
Overall Weight	14 Gallon: 76 lbs	

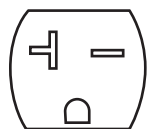

The Supercell requires a 20 Amp outlet receptacle to be installed by a licensed electrician.



The Supercell Turbo requires a 30 Amp outlet receptacle to be installed by a licensed electrician.



The Supercell Turbo requires that it be installed to a 30 Amp breaker (minimum) by a licensed electrician.



The Export Supercell requires that it be installed to a 20 Amp breaker (minimum) by a licensed electrician.

System Dimensions

Nominal dimensions shown. Dimensions subject to slight variations in manufacturing. Mounting dimensions allow for 13/16" clearance when removing and emptying the drum

Allow for an additional 24" of clearance above the Motor Assembly to allow for its removal during filter replacement and other maintenance. Allow for an additional 3" of clearance around the system for ease of access to the latches.

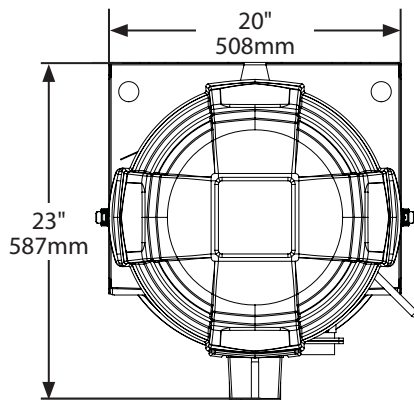

The Supercell requires a 20 Amp outlet receptacle to be installed by a licensed electrician. The Supercell Turbo requires a 30 Amp outlet receptacle to be installed by a licensed electrician. See below outlet receptacles needed based on your unit.

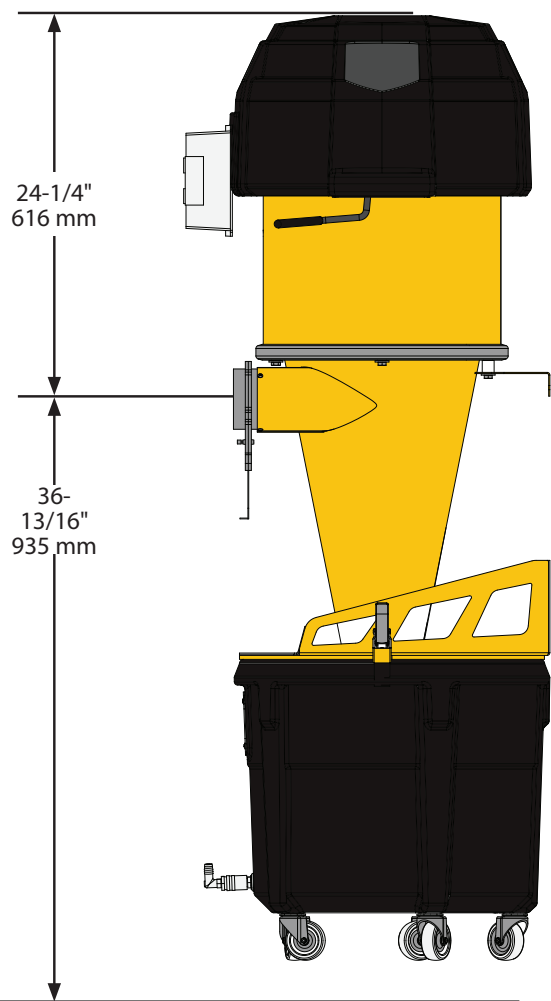
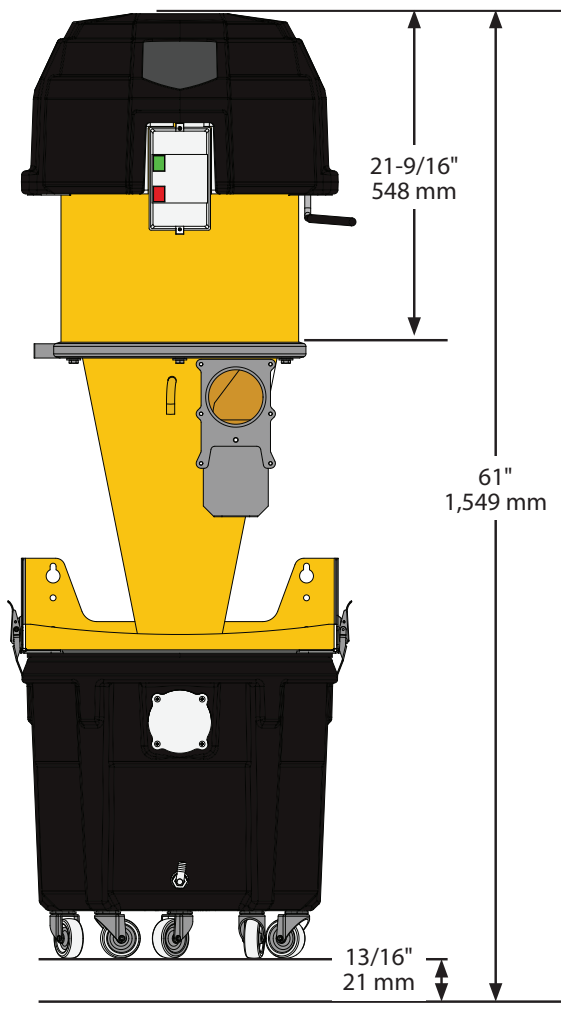
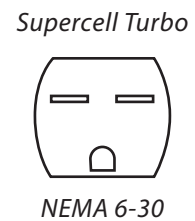
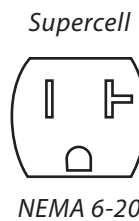

System Contents



If you cannot find an item on the list, examine the packaging materials very carefully for nested items. Please note that certain components have been pre-installed. There may be hardware leftover.

ID	Part number	Part description	Qty
A	BXI001501 BXI441501 EXP-BXI501501	Supercell Motor Assembly Supercell Turbo Motor Assembly Export Supercell Motor Assembly	1
A1*	WCW000008	Antenna Extension Wire	1
A2*	WCW000003	Dust Sentry Cord	1
A3*	-----	Power Cord	1
B	FPX040001	Filter Hold Down Plate	1
C	FCS131040H	13" x 13" Conical HEPA Cartridge Filter	1
D	GCZ150000	15" Ring Clamp	1
E	SCX040000	Cyclone	1
E1*	DGA040000	4" Aluminum Blast Gate	1
E2*	DAB040000	4" Male Duct Adapter	1
E3*	AFR316066	Rivets	5
F	SMS040001	Supercell Wall Bracket	1
G	AHX000021	Supercell 14 Gal. Model Hardware Pack	1
G1	ZBT040001	Supercell Wall Bracket Template	1
G2	RGF000015	15" Barrel Gasket	1
G3	RGZ051820	Supercell Flange Gasket	1
G4	AFS015920	1/4"-20 x 3/4" Hex Head Bolt	6
G5	AFW025000	1/4" Flat Washer	6
G6	AFT900006	1/4"-20 Nylock Nut	6
G7	AFB155180	5/16-18 x 2-1/2" Hex Head Bolt	4
G8	AFW180000	5/16" Flat Washer	4
G9	AFW180516	5/16" Rubber Washer	4
G10	AFT155175	5/16" Whiz-Lock Nut	4
G11	AFT900516	5/16" - 18 Nylock Nut	4
G12	AFW516075	5/16x 3/4" Nylon Spacer	1
G13	SMS040000	Rear Support Brace	1
G14	AFL990001	Latches	2

ID	Part number	Part description	Qty
G15	AFS501032	10-32 1/2" Phillips Pan Head Screws	4
G16	AFT901032	10-32 Nylock Nut	4
G17	AFB155180	5/16-18 x 2-1/2" Hex Head Bolt	2
G18	AHX000033	Tubing Assembly	7
G18A	VRV050500	1/2" ID Clear Vinyl Tubing	1/3'
G18B	AWV000050	1/2" ID Switch Valve	1
G18C	VRV050500	1/2" ID Clear Vinyl Tubing	7'
G19	ACH000058	Double Spring Clamp	1
G20	AHX000018	Quick Disconnect Kit	1
G20A	RLH000006	1/4" NPT Nylon Elbow	1
G20B	RLH000005	3/8" Socket	1
G20C	RLH000004	3/8" Male Plug	1
G20D	RLH000002	Nylon Washer	1
G20E	RLH000003	Rubber O Ring	1
G20F	RLH000007	Nylon Nut	1
G21	AXD600300	9-17 Gallon Drum Liner Bag	5
G22	RLH000023	23 mm Button Plug	1
G23	ACB640000	4-1/2" Turn-Key Band Clamp	2
G24	RGZ470114	Bin Gasket	4
G25	AMR000000	Remote Control Key Fob	1
H	DHF042502	4" x 25' Vacuum Pressure Rated Flex-Hose	1
I	AXB999110B	Dust Sentry Automatic Bin Level Indicator	1
J	SMD140400	Drum Assembly	1
J1	SDS140000	14 Gallon Molded Drum	1
J2*	RHL000604	Drum Window	1
J3*	AFS103258	10-32 5/8" Phillips Pan Head Screws	4
J4*	AFT901032	10-32 Nylock Nuts	4
J5	RHC000012	3" Caster with 5/16"-18 x 3/4" Stems	5

Please unpack the parts carefully and confirm you have received each item listed here.

* Some components are pre-installed at the factory and are listed here for your convenience.

System Contents (Continued)

Filter Attachment Hardware

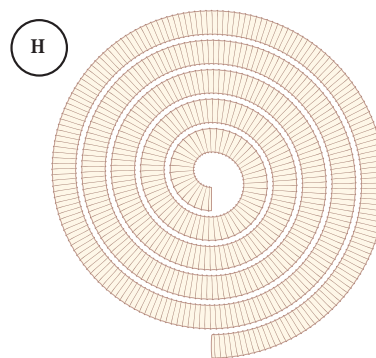
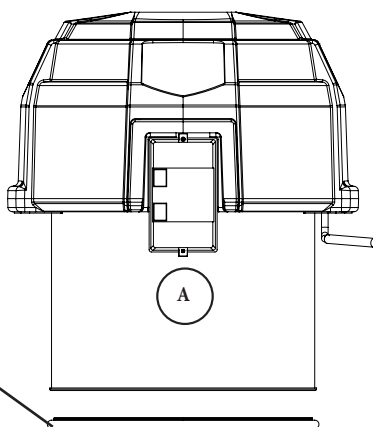
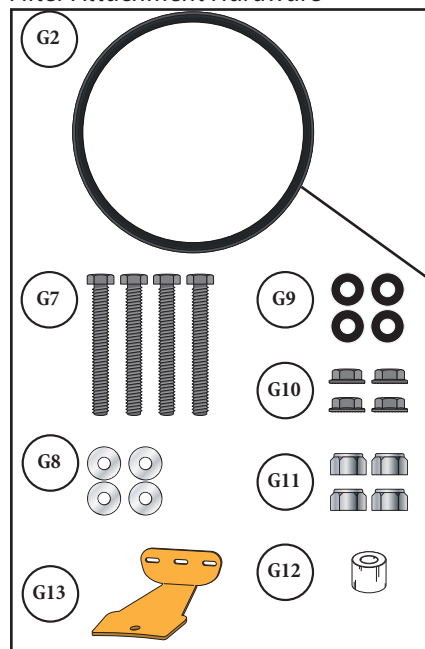

Filter Attachment Hardware

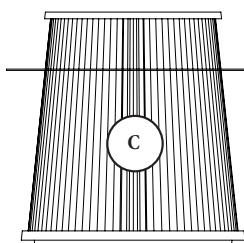
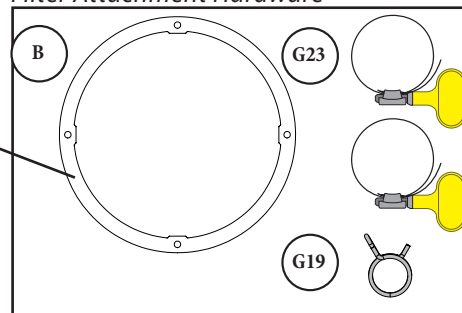

Mounting Hardware & Remote

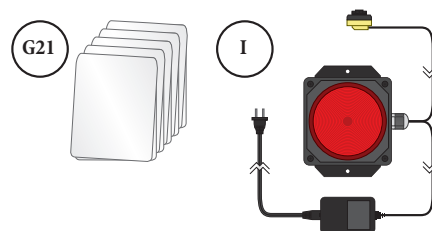
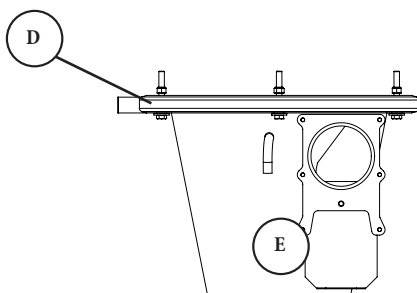
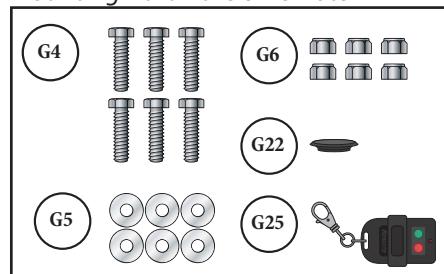

Drum Hardware

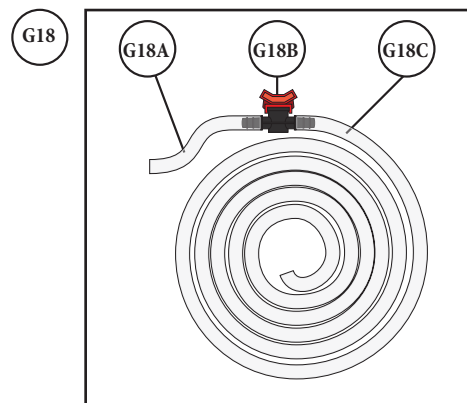
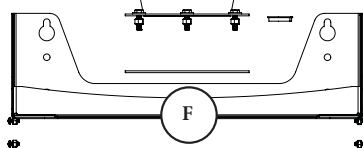
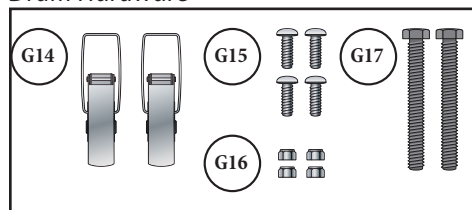

Owner's Manual Envelope

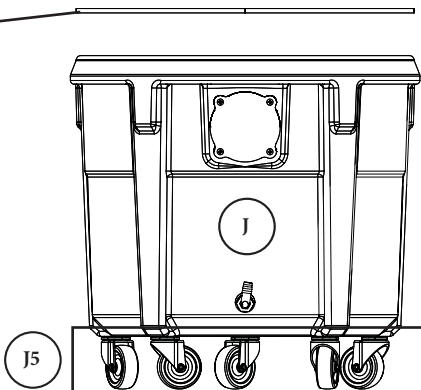
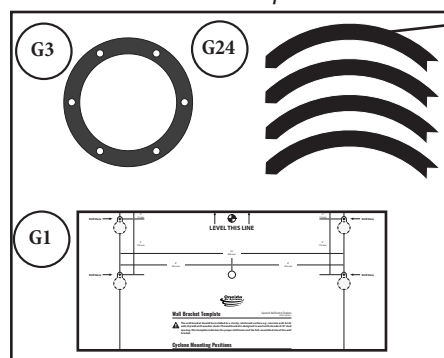

Vent Tube Quick Disconnect Pk

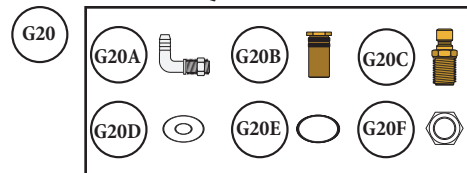

Assembly Instructions

You will need the following tools:

WALL MOUNTING BRACKET		CYCLONE BODY	DRUM LATCHES
Stud Finder	Light Adhesive Tape	7/16" Wrench	3/8" Wrench
Tack / Center Punch / Nail	Tape Measure / Ruler	7/16" Socket Wrench	#2 Phillips-Head Screw Driver
Wall Mounting Fasteners *	Level	1/2" Wrench	
Power Drill	Pencil / Marker	1/2" Socket Wrench	
Drill Bit (for your wall fastener)			

*You will need to supply your own wall mounting hardware. Use appropriate fasteners for the wall type you are installing your system onto (e.g. lag bolts, drywall anchors, etc.).

- 1 Installing the Bin Gasket (G24) onto the Wall Bracket (F).
 - a. Turn the Wall Bracket (F) upside down [FIG. 1a].
 - b. Lay out the four Bin Gasket segments (G24). DO NOT REMOVE THE BACKER TAPE [FIG. 1b].
 - c. Arrange the Bin Gasket segments (G24) in a circle with the ends interlocking and aligning to the rounded front edge of the wall bracket [FIG. 1c].
 - d. Carefully mark a circle around the inside of the arranged Bin Gasket segments (G24) with a marker to create a reference line [FIG. 1d].
 - e. Peel the backer tape off of the Bin Gasket segments (G24) and adhere them to the Wall Bracket (F), lining them up with your reference line [FIG. 1e].

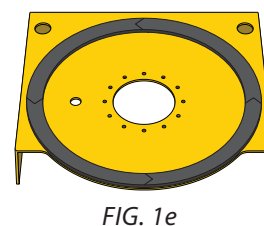
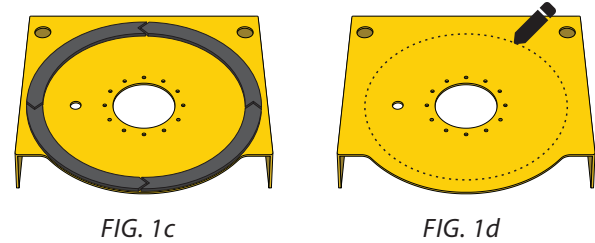
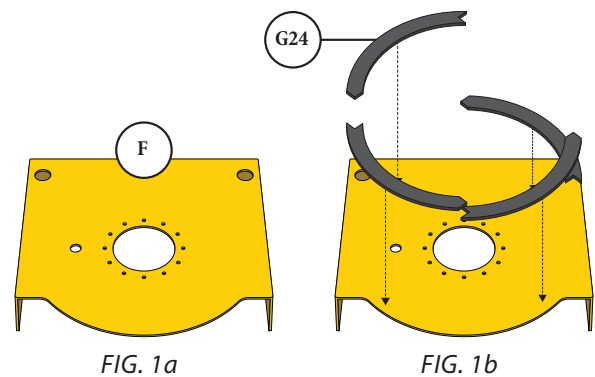

Note: Press each gasket piece firmly onto the bracket to ensure a long-lasting, airtight seal.

Assembly Instructions (Continued)

2

Align the Latches (G14) onto the holes on either side of the Wall Bracket (F) and secure them in place using two Pan-Head Screws (G15) and Nylock Nuts (G16) [FIG 2].

Note: Firmly tighten this hardware. You may need to open the latch to access the screw holes for mounting. Allow for an additional 3" of clearance around the system for ease of access to the latches.

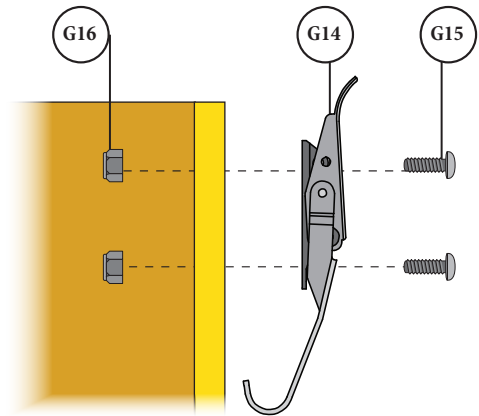

FIG. 2

3

Identify where you will install the Supercell in your shop. It must mount to a reinforced wall (studs, concrete, etc.) and is designed to accommodate standard 16" stud spacing.

Center the wall bracket Template (G1) between your wall studs [FIG. 3].

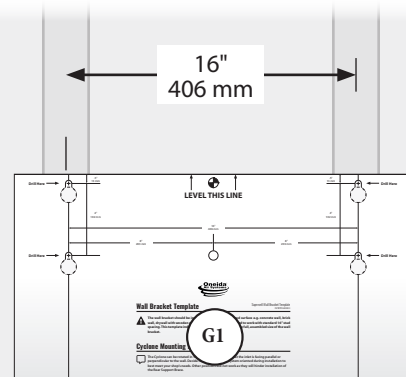

FIG. 3

4

Mark a straight level line 26-5/8" from the ground. Align the top of the Template (G1) with the marked line [FIG. 4] and temporarily secure the Template (G1) to the wall with a tack or non-marking tape.

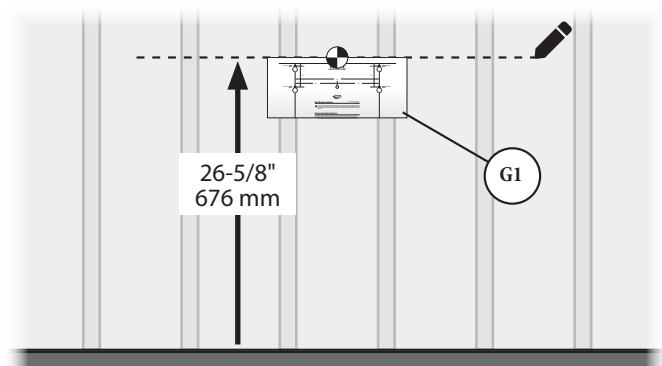

FIG. 4

Assembly Instructions (Continued)

5

Place a mark through the Template's (G1) paper at each indicated crosshair (four keyway holes and one center hole), then remove the Template (G1) from the wall [FIG. 5a].

Measure 15-1/4" straight up from the center hole mark and mark a straight level line to help with the install of the Rear Support Brace (G13) [FIG. 5b].

Note: The line you have marked for the Support Brace is where the fasteners will be installed to. Refer to Step 10 for more information.

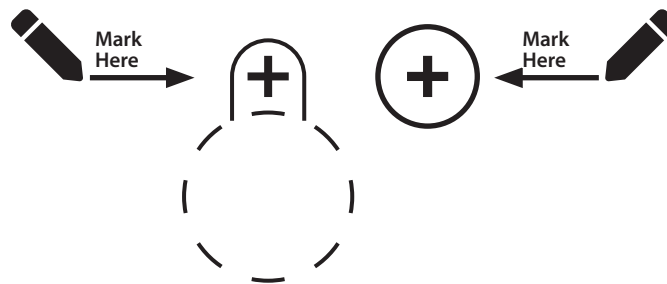

FIG. 5a

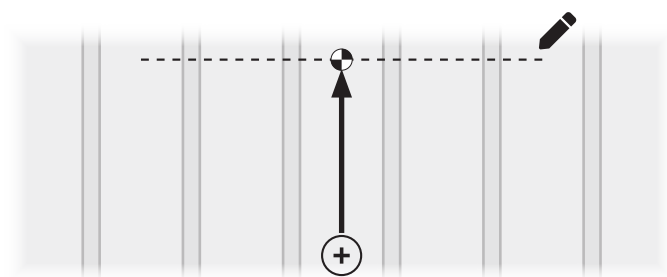

FIG. 5b

6

Using appropriate fasteners for the wall type you are installing your system onto, drill into and install fasteners into the wall at all marked locations [FIG. 6].

- Maximum Fastener Size: 5/16" diameter for the 4 keyholes
- Maximum Fastener Size: #12 screw for the rear support brace holes
- Maximum Washer Size: 3/4" outside diameter

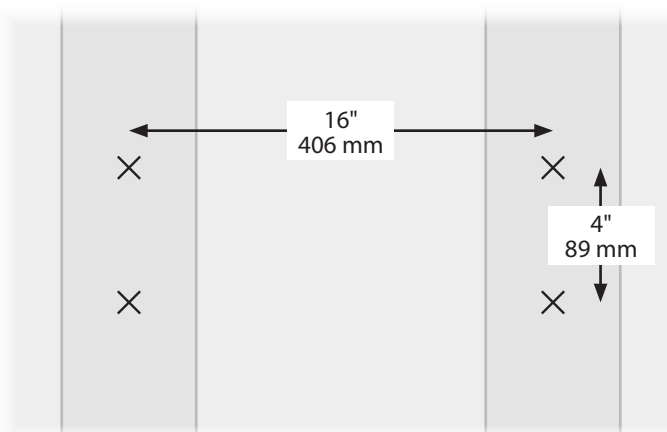

FIG. 6

7

Place washers onto each fastener and thread the fasteners into all four holes, leaving at least 1/2" outside of the hole to fit the Wall Bracket (F) and Rear Support Brace (G13) [FIG. 7].

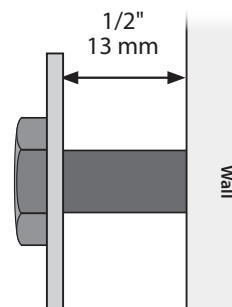

FIG. 7

Assembly Instructions (Continued)

8

Lift the Wall Bracket (F) up and over the fasteners so that the washer is on the inside of the bracket. Slide the Wall Bracket (F) down so that the fastener is snugly inside the smaller section of each keyhole [FIG. 8].

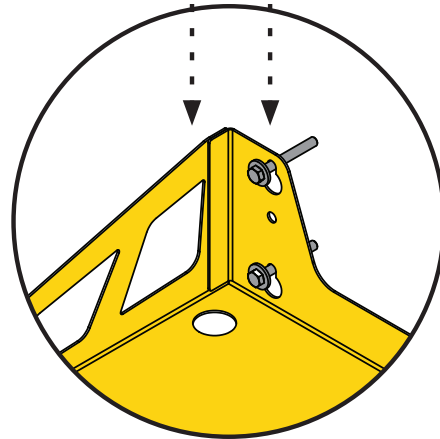

FIG. 8

9

Tighten these four fasteners to secure the Wall Bracket (F) to the wall [FIG. 9].

Note: If installing over drywall, avoid overtightening as it may damage the wall.

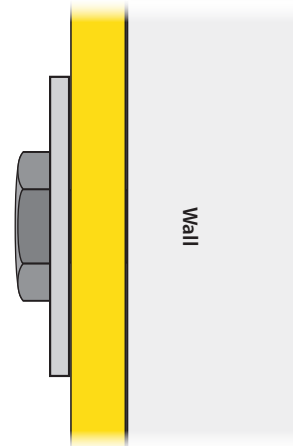

FIG. 9

10

Fasten the Rear Support Brace (G13) to the wall using your own suitable hardware [FIG. 10]. Refer to the previously marked line for the suitable mounting location of this Brace.

Note: This hardware is not load bearing and only needs to connect the brace to the wall to add additional support to the system during operation. Fasten through at least one hole.

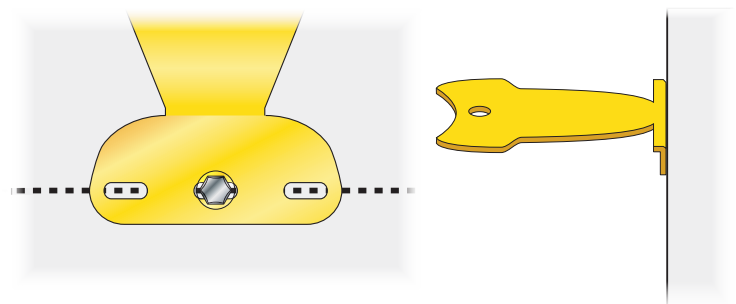

FIG. 10

Assembly Instructions (Continued)

- 11** The Cyclone (E) can be rotated so that the inlet is facing parallel or perpendicular to the wall. Decide how you want your system oriented [FIG. 11].

Note: The cone's inlet can be rotated in 90-degree increments to best connect to your ductwork and/or tools. Other positions will not work as they will hinder installation of the Rear Support Brace.

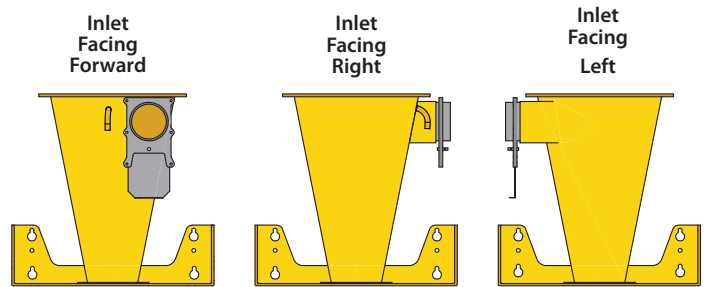

FIG. 11

- 12** Align the Rear Support Brace (G13) underneath the hole closest to the wall on the upper flange of the Cyclone (E) [FIG. 12].

Note: Ensure there is room between the Rear Support Brace and the Cyclone's hole for the Nylon Spacer (G12) used in Step 14.

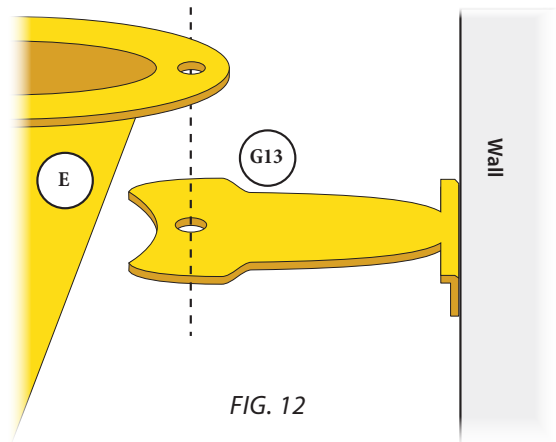

FIG. 12

- 13** Place the Flange Gasket (G3) and the Cyclone (E) onto the Wall Bracket (F) and align the hole patterns on all three items. Secure together using six Hex Head Bolts (G4), six Flat Washers (G5), and six Nylock Nuts (G6) [FIG. 15].

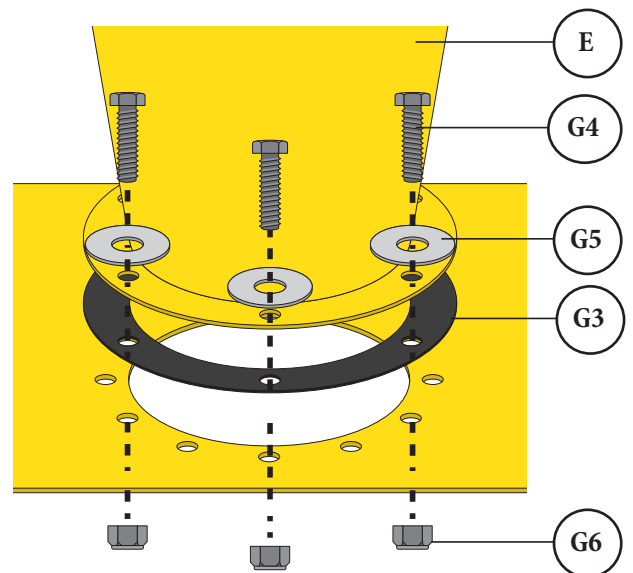

FIG. 15

Assembly Instructions (Continued)

- 14** Secure the Rear Support Brace (G13) to the Cyclone (E) using a 2-1/2" Hex Head Bolt (G7), Flat Washer (G8), Nylon Spacer (G12), Rubber Washer (G9), and Whiz-Lock Nut (G10) as shown in [FIG. 13].

Note: Ensure that the Whiz-Lock Nuts are torqued down so that the rubber washers are firmly compressed - this will prevent air leaks.

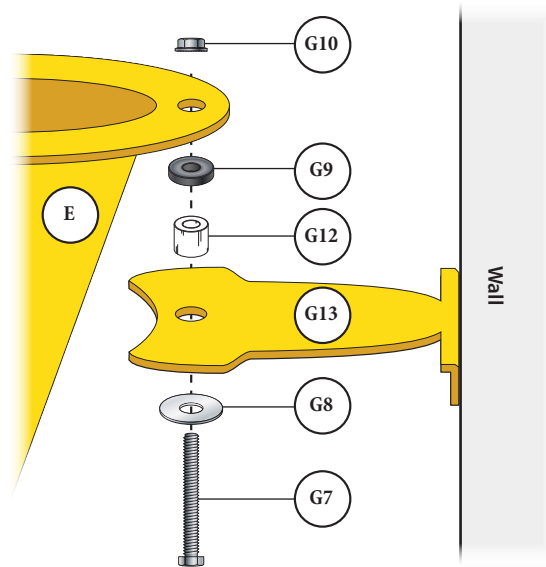

FIG. 13

- 15** Install the three remaining Hex Head Bolts (G7), Flat Washers (G8), Rubber Washers (G9), and Whiz-Lock Nuts (G10) to the three remaining holes in the Cyclone's (E) upper flange [FIG. 14].

Note: Ensure that the Whiz-Lock Nuts are torqued down so that the rubber washers are firmly compressed - this will prevent air leaks.

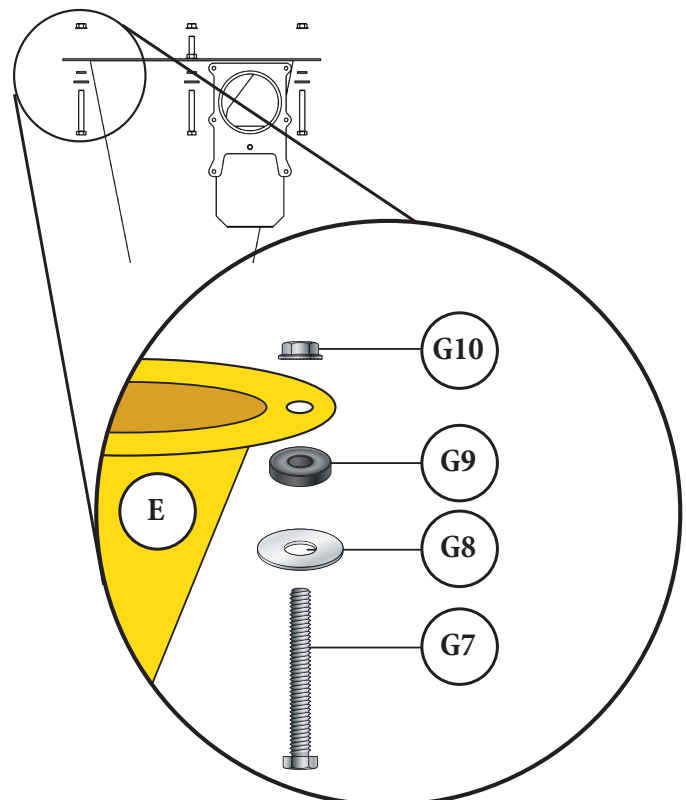

FIG. 14

Assembly Instructions (Continued)

16

Place the Filter (C) on top of the Cyclone (E) with the open side facing down [FIG. 16].

Note: Position the Filter (C) on the Cyclone (E) so that it is centered between all four Hex Head Bolts (G8).

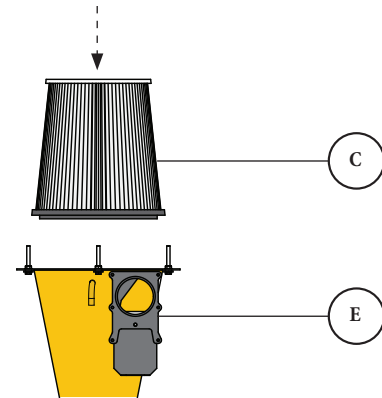

FIG. 16

17

Slide the Filter Hold-Down Ring (B) over the Filter (C) and the previously installed bolts (G7) and secure in place using four Nylock Nuts (G11) [FIG. 17].

Note: Tighten hardware so that the Filter's pre-installed foam gasket is firmly compressed (by roughly 50%).

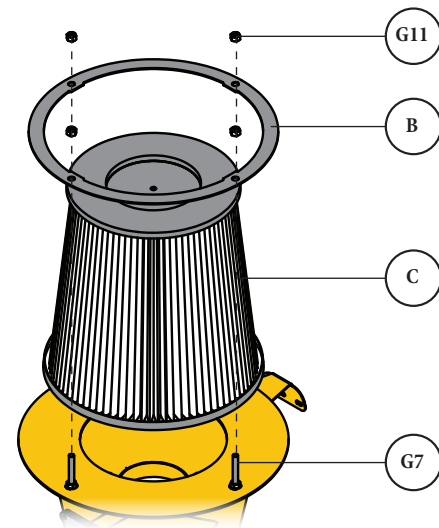

FIG. 17

18

Open and slide the Ring Clamp (D) over the assembly so that it rests outside the upper flange of the Cyclone (E) [FIG. 18].

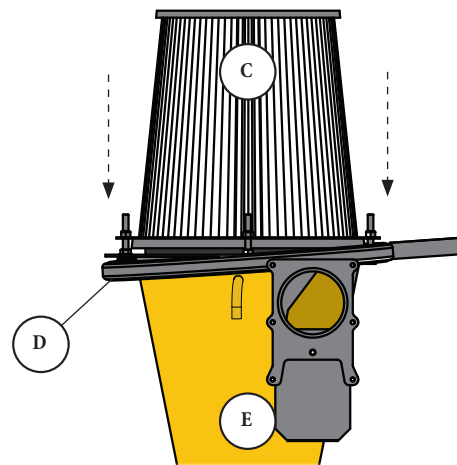

FIG. 18

Assembly Instructions (Continued)

19

Using pliers, squeeze and open the Double Spring Clamp (G19) and slip it onto the shorter end of the Tubing Assembly (G18A). Then, with the clamp still open, slide the Tube Assembly (G18) onto the vent tube near the Cyclone's (E) inlet, closing the Spring Clamp once the hose is fully seated [FIG. 19a].

Note: If you are not using the automatic bag holding feature of the system, the Switch Valve (G18B) of the Tube Assembly MUST be in the closed position [FIG 19b]. Otherwise leave the Tube Assembly in the open position [FIG 19c].

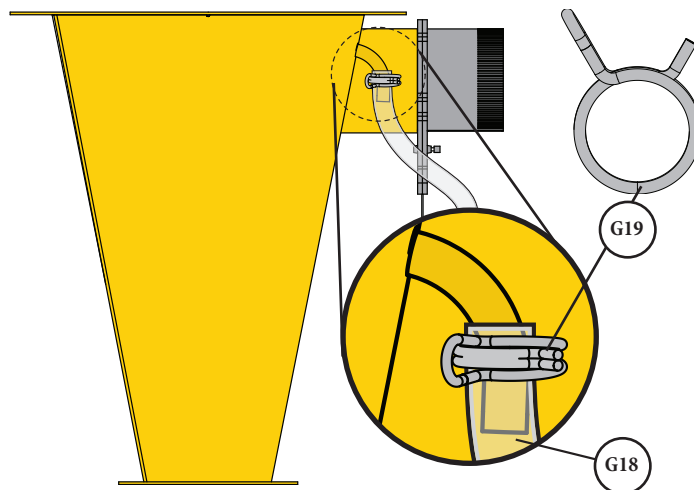

FIG. 19a

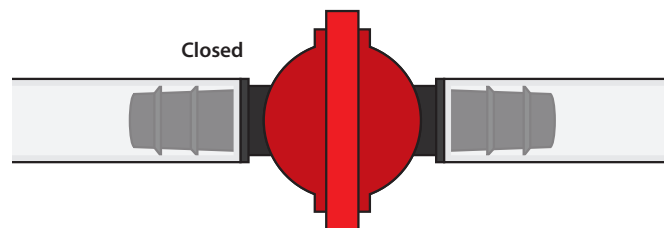

FIG. 19b

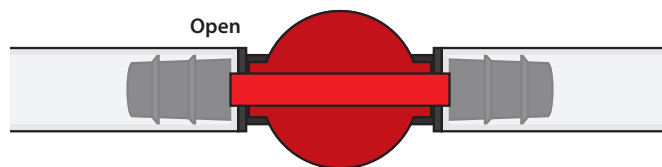

FIG. 19c

20

Install the Barrel Gasket (G2) onto the rounded, bottom edge of the Motor Assembly (A). The Barrel Gasket (G2) should be oriented so that the "ribbed" side is facing downwards [FIG. 20].

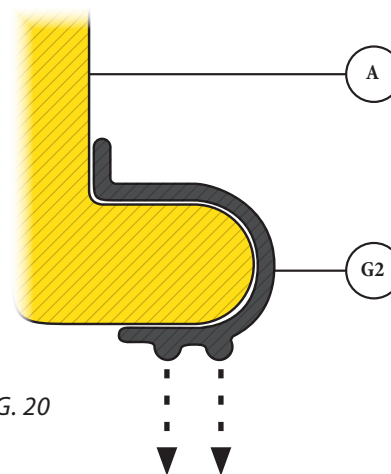

FIG. 20



DO NOT TURN ON OR PLUG IN YOUR DUST COLLECTOR UNTIL INSTALLATION IS COMPLETED. NEVER RUN THE SYSTEM WITHOUT THE MOTOR COWLING IN PLACE.

Assembly Instructions (Continued)



THE MOTOR ASSEMBLY IS HEAVY AND CUMBERSOME; BE SURE TO HAVE ADEQUATE HELP WHEN LIFTING!

21

Carefully lift the Motor Assembly (A) up and over the Filter (C) and down onto the Cyclone's (E) upper flange. Align the Motor Assembly so its perimeter is flush with the Cyclone's (E) flange below it [FIG. 21].

Note: The Motor Assembly can be freely rotated to best position the Magnetic Starter and Pulse Bar to suit your needs. Some positions will not work as these items may impact with the wall.

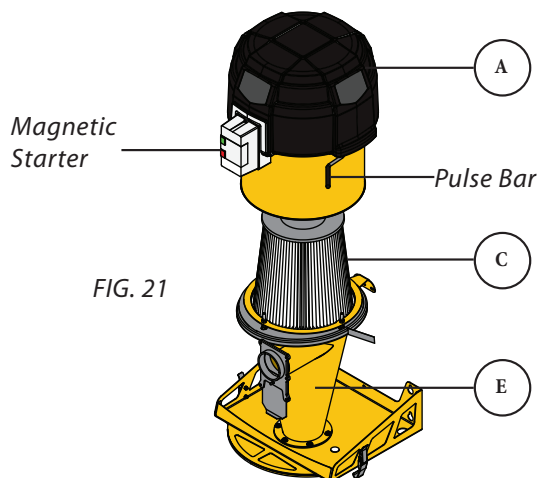

22

Lift and close the Ring Clamp (D) over the Barrel Gasket (G2) and the Cyclone's (E) upper flange.

Secure the Ring Clamp (D) using the Clamp's cotter pin [FIG. 22].

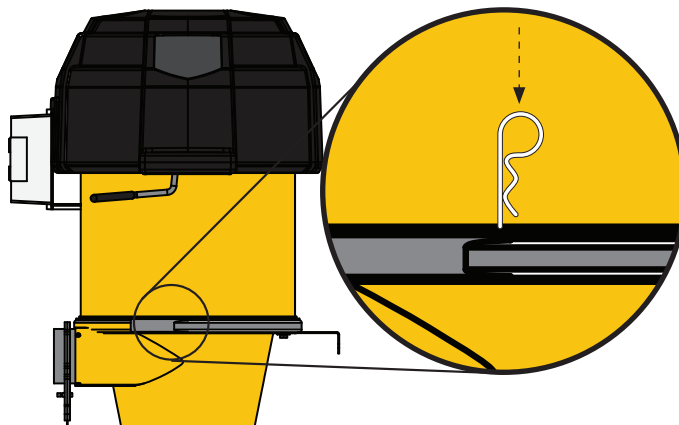

FIG. 22

23

Take the Tubing Assembly (G18) and route it through the closest retaining hole located in the back corner of the Wall Bracket (F) [FIG. 23].

Note: Which hole you use will be determined by the orientation of your Motor Assembly (A). Use whichever hole is closest to ensure adequate length for the Tubing Assembly (G18) to connect to the Drum (J1).

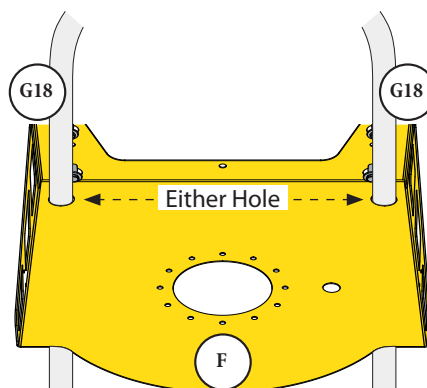

FIG. 23

Assembly Instructions (Continued)

24

Connect the Dust Sentry's power adapter (I) to the Dust Sentry Cord (A2) on the Motor Assembly's (A) magnetic starter [FIG. 24]. The Dust Sentry's strobe light (I) should be mounted in a highly visible area using adhesive strips or the two mounting holes.

- Refer to the *Dust Sentry Installation Sheet* for more information.

Note: Discard your Dust Sentry's 110V power cable if you're using the Dust Sentry Cord (A2). The Dust Sentry's location is limited by the two wires extending from the Strobe Light and must have sufficient length to install in the pre-cut hole on the Wall Bracket (F).

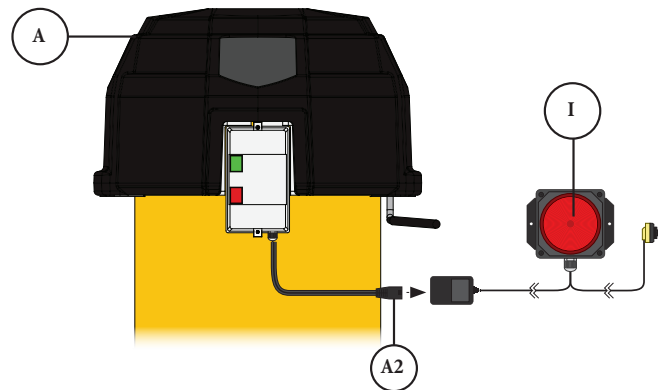

FIG. 24

25

Install the Dust Sentry's (I) infrared sensor (I) to the pre-cut hole on the Wall Bracket (F). FIG. 25].

- Refer to the *Dust Sentry Installation Sheet* for more information.

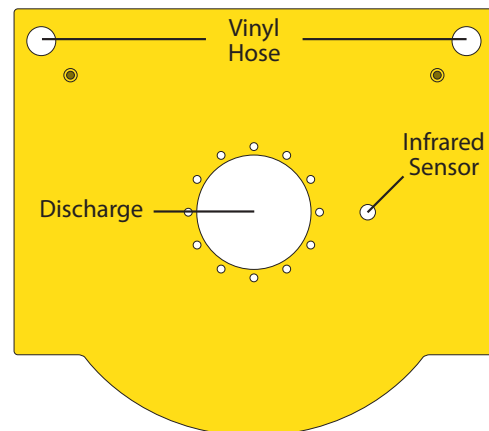

FIG. 25

26

Insert 2 Hex Head Bolts (G17) down through the threaded inserts on the Wall Bracket (F). Finger tighten only [FIG. 26].

Note: These will protrude down from the Wall Bracket and help position the 14-gallon bin directly underneath the cyclone.

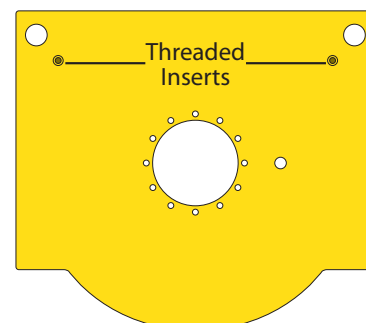

FIG. 26

Assembly Instructions (Continued)

27

Install the Quick-Disconnect Kit (G20) onto the pre-drilled hole near the bottom section of the Drum (J1) [FIG. 27a].

- Refer to the **Quick Disconnect Installation Sheet** for more information.

Note: If you are not using the automatic bag holding feature of the system, the Valve of the Tube Assembly MUST be in the closed position [FIG. 27b].

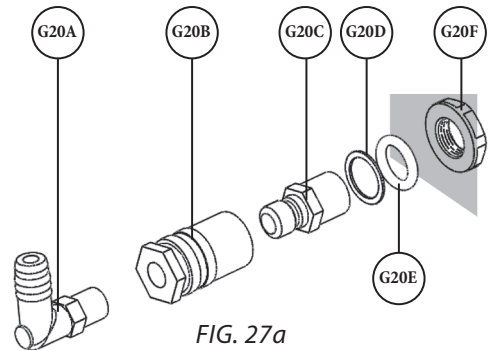

FIG. 27a

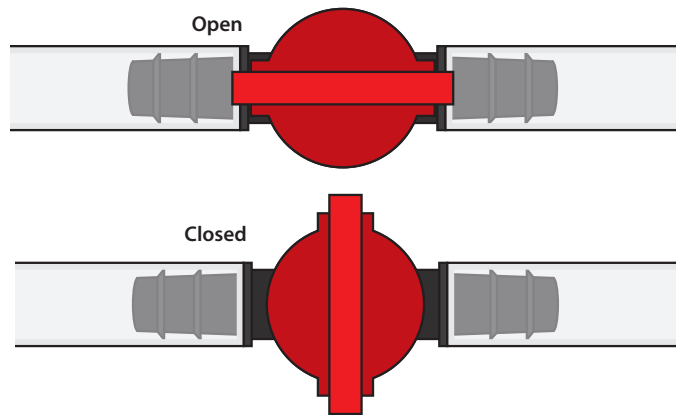

FIG. 27b

28

Take each of the five Casters (J5) and thread them into the holes located underneath the Drum (J1) [FIG. 28].

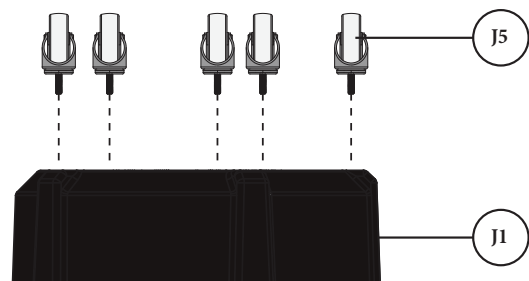

FIG. 28

29

Place a Liner Bag (G21) inside the Drum (J1). Take care to ensure that the bag is fully expanded to the inside of the Drum (J1) and that the upper edge of the Liner Bag is folded out and over the lip of the Drum [FIG. 29].

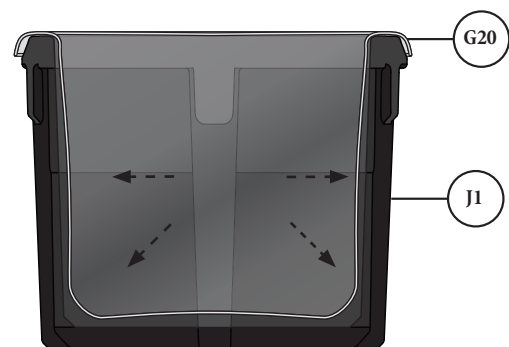

FIG. 29

Assembly Instructions (Continued)

30

Attach the long end of the Tube Assembly (G18C) onto the Nylon Elbow (G20A) installed on the lower section of the Drum (K). Push the Hose onto the fitting so that all barbs are covered [FIG. 30].

Note: If you are not using the automatic bag holding feature of the system, the Valve of the Tube Assembly MUST be in the closed position.

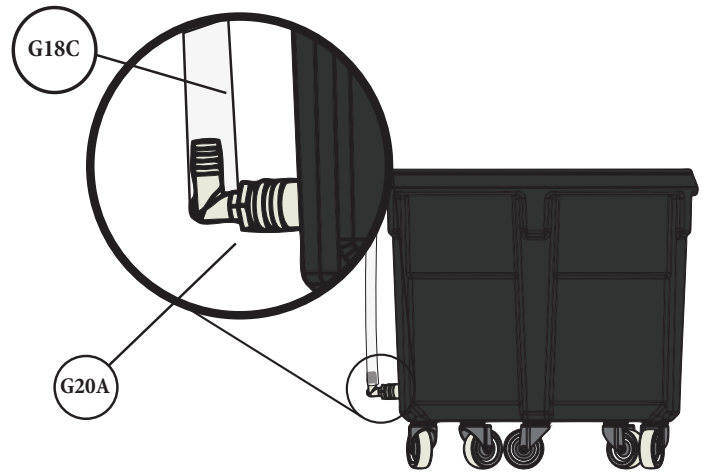

FIG. 30

31

Center the Drum Assembly (J) underneath the Wall Bracket (F) and lower the Latches (G14) so that they hook underneath the rim of the Drum (J) [FIG. 31]. The Latches (G14) can then be closed to lift the drum up from the ground and seal the dust collector for operation.

Note: Be sure to rotate the Drum to ensure that you can easily see the pre-installed fill viewing window. The Hex Head Bolts (G17) installed in Step 26 are guides for positioning the Drum during latching. The back rim of the Drum should be in light contact with both Hex Head Bolts as the Drum is lifted up and latched.

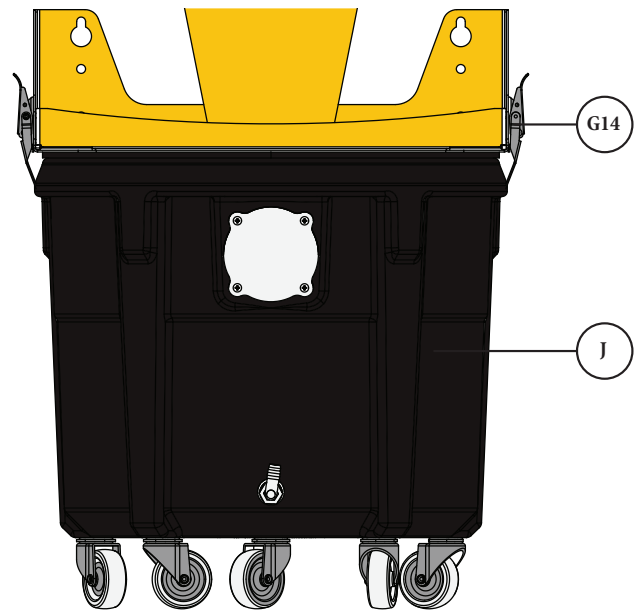

FIG. 31

Assembly Instructions (Continued)

32

Uncoil and hang the Antenna Extension Wire (A1) either on the ceiling or high up on the wall [FIG. 32].

Note: Obstructions and distances can interfere with the remote's radio frequency signals.

Common sources of interference include:

- a. *Distance: The ideal distance is 50' from the Supercell.*
- b. *Obstructions: Walls, benches, and other machines can reflect or absorb the signal.*
- c. *Electromagnetic interference (EMI): Machines, LED Lamps, and other electronic devices may create an interference in the signal.*

Tips on how to optimize the range of your remote:

- a. *Line of Sight: Hold the remote at eye level and direct the remote at the Supercell.*
- b. *Extend the wire: The antenna wire can be further extended using a 20-gauge wire.*

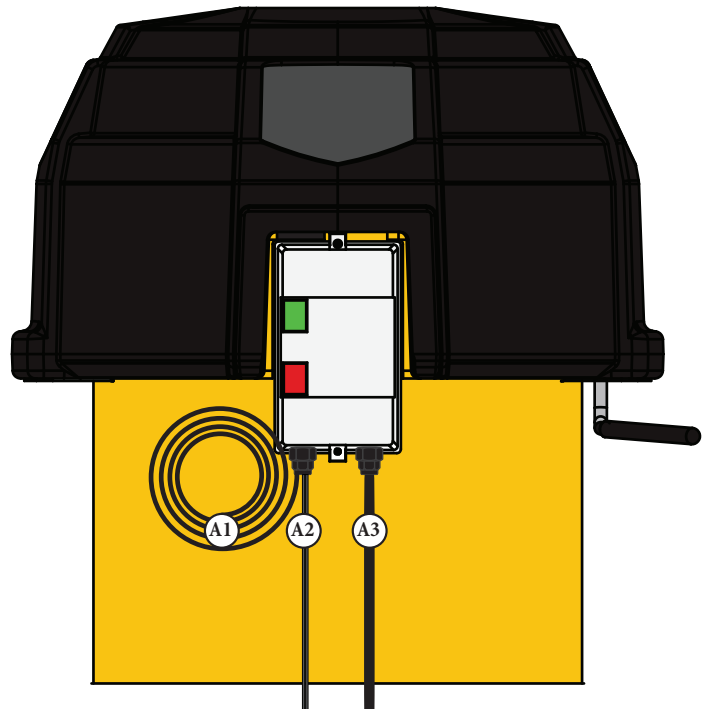

FIG. 32

33

The Remote (G25) sends long range wireless signals via radio frequency that work at long distances. The Antenna Extension Wire (A1) further extends the distance for the remote [FIG. 32 & 33a].

The Dust Sentry (A2, I) uses infrared technology to automatically detect when the dust bin is full [FIG. 32 & 33b].

The Power Cord (A3) powers the system on and off [FIG. 32 & 33c].

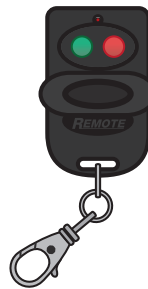

FIG. 33a

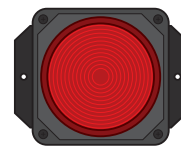

FIG. 33b

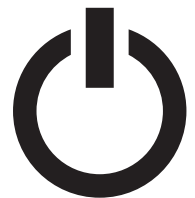

FIG. 33c

Assembly Instructions (Continued)



ONLY USE VACUUM PRESSURE RATED FLEX-HOSE AND DUCT WITH THE SUPERCCELL DUST COLLECTOR. UNDER THE SYSTEM'S HIGH SUCTION, STANDARD HOSE/PIPE MAY COLLAPSE CAUSING AFFIXED TOOLS TO BE PULLED TOWARDS THE SYSTEM, POTENTIALLY CAUSING DAMAGE AND/OR INJURY.

34

Connect the Supercell to your tools or ductwork using the Vacuum Pressure-Rated Hose (H). Secure the hose in place using Hose Clamps (G23) at both ends [FIG. 34].

Note: Refer to the FAQ section for additional recommendations on how to connect your collector to your layout.

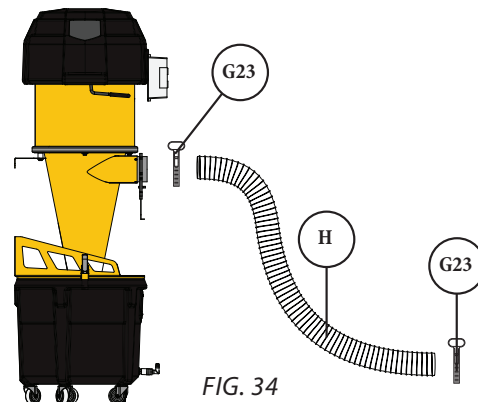

35

Plug in your collector and turn on the magnetic starter mounted on the Motor Assembly (A) [FIG. 35a].

Installation is complete! Open the inlet's blast gate to begin collecting dust from your tools.

Note: Refer to the Supercell/Supercell Turbo System Specifications section for further plug and outlet recommendations [FIG. 35b].

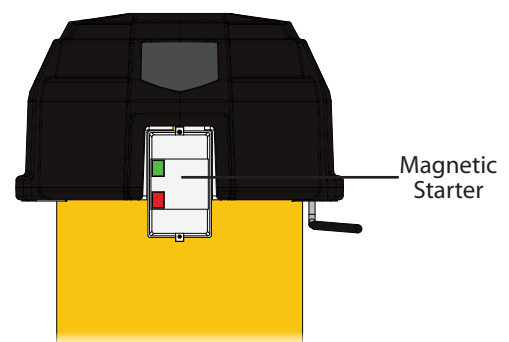
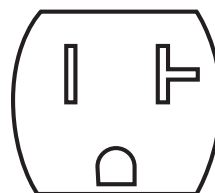

FIG. 35a

Supercell



NEMA 6-20

Supercell Turbo

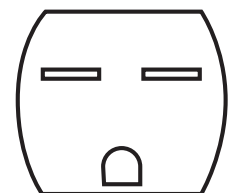

NEMA 6-30

FIG. 35b

Maintenance



UNPLUG YOUR UNIT BEFORE SERVICING OR CLEANING. KEEP THE TOP VENTS IN THE COWLING CLEAN. THESE ARE FOR BOTH EXHAUST AND INCOMING COOLING AIR FOR THE MOTOR.

Filter Pulse Bar Cleaning

The Pulse Filter System helps to unclog the filter for improved airflow and performance. If air flow is not restored after pulsing, check for clogs and clean filter. (Review Cleaning the Filter and Troubleshooting Sections).

1. Pulse your filter regularly—including multiple times per day when collecting fine dust—or when you notice decreased airflow. Frequent pulse cleaning of the filter will keep your performance optimal.
2. While the unit is running, close the Blast Gate on the inlet of the Cyclone. Once closed, push down the Pulse Bar extending out of the cowling, past the initial resistance, and hold for a few seconds then release the Pulse Bar. Repeat five times.

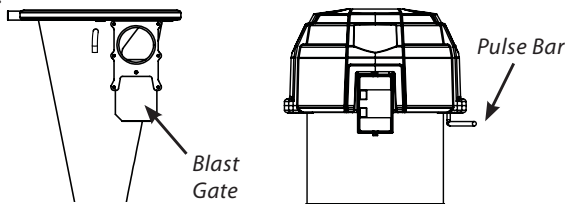

3. Open Blast Gate to resume normal operation.

Cleaning the Filter

We recommend pulsing the Filter regularly – at minimum before you start to work and when you are finished for the day. If performance has decreased and pulsing does not restore airflow, the Filter should be replaced.

1. Wear a dust mask and eye protection.
2. Turn off and unplug the dust collector and wait for the fan blower to come to a complete stop and for the dust to settle.
3. Unlatch the Ring Clamp (D) at the base of the motor section and allow it to hang freely. Remove the motor section and set aside.

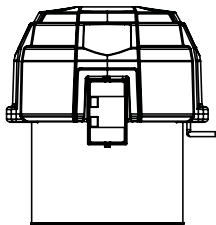

4. Use a hand-held, compressed air nozzle with a pressure up to 90 PSI max to blast air along the filter's exterior pleating.

Hold the air nozzle at a 20 degree angle and at least 2" away from the filter; closer blasts will damage the filter material. Direct air out and away from anyone in the area. Do not use this method when any hazardous material has been vacuumed up.

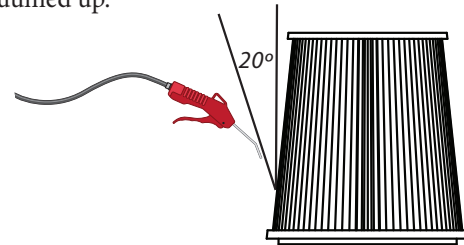

5. Check to make sure filter is in good condition with no torn media or cracks or tears in the seal. A broken filter can leak material into the motor and cause severe damage! You cannot operate the system without a proper filter in place. (See Accessories page for the replacement filter part.) Operating without a sufficient filter will cause severe damage to the motor and will void the warranty!

Note: To help see damage from the outside, shine a flashlight from the inside. If the filter is removed after it's been in service for some time, the gasket may no longer return to its original thickness. In this case, ensure enough gasket thickness remains for proper sealing to prevent dust from escaping

6. If the filter isn't in good condition, remove the Filter (C) by removing the four 5/16-18 Nylock Nuts (G11) and the Filter Hold-Down Ring (B) by sliding it over the filter. Dispose of the old filter in the same way you would dispose of the dust you've been collecting.
7. Center new Filter (C) over the center of the Cyclone (E) and place the Filter Hold-Down Ring (B) over the Filter (C) and re-secure using the four 5/16-18 Nylock Nuts (G11.) Tighten hardware so that the Filter's pre-installed foam gasket is firmly compressed (by roughly 50%). **DO NOT OVERTIGHTEN.**

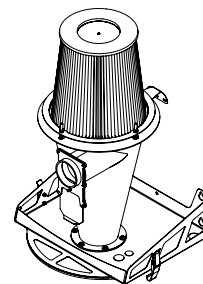

8. Replace the motor section and re-latch the drum clamp around the motor section.

Maintenance (Continued)

Emptying the Drum

When first using the dust collector, check the Drum Window (J1) regularly to get an idea of how often it needs to be emptied. If the Drum (J) becomes overfilled, the dust will be sucked into the Cone (E) and into the Filter (C). To clean the Drum Window, **ONLY** use a clean, soft cloth. **NEVER** use solvents. Using a flashlight will make viewing the dust levels easier.

1. Wear a dust mask and eye protection.
2. Turn off the dust collector and wait for the fan blower to come to a complete stop and for the dust to settle before unlatching the drum from the cyclone body.
3. Dispose of waste safely and properly.
4. Replacement bags should be 22" x 22" and at least 1.5 mils thick. See Accessories page for replacement bags needed for your system.

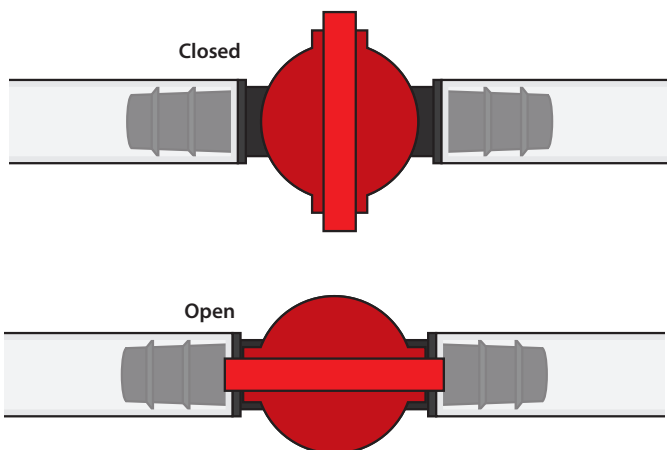
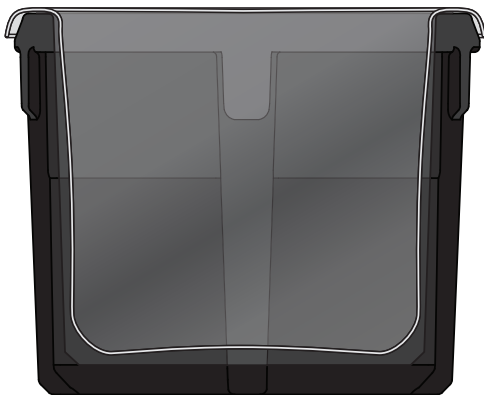

Cleaning out the Cyclone

If the drum becomes overfilled and the cone is packed with dust:

1. Wear a dust mask and eye protection.
2. Turn off the dust collector and wait for the fan blower to come to a complete stop and for the dust to settle before unlatching the drum from the cyclone body.
3. Empty Drum (K) and reinstall as directed. Try to get contents of cone to fall down into drum. Follow directions under "Cleaning the Filter". If the Cone and Filter are packed so that dust won't flow down into the drum on its own then unclamp the motor section and set aside.

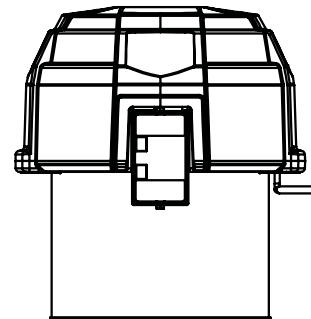

4. Remove the filter by removing the four Nylock Nuts and the Filter Hold-Down Ring.
5. Note: Review Cleaning the Filter Section for a detailed step by step.
6. The top of the cyclone can now be accessed to allow debris to drop down into the drum/bin.

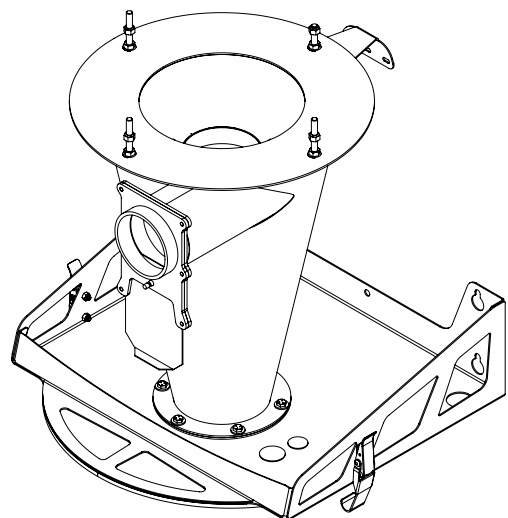

F.A.Q.

What dust can be collected?

Oneida Air Systems' dust collectors are designed and tested for wood and wood dust. They can and have been used effectively for various other dusts and chips, such as drywall dust, paper dust, agricultural dust, metal chips and other forms of debris. The customer is, however, cautioned that some common materials when cut, ground or processed by machinery may become very dangerous: highly toxic, flammable, or deflagrable and explosive. The user must ensure that the dust collection system is used in accordance with national, state, local, NFPA, OSHA and all other applicable codes.

Can this be used for wet applications?

No. This system is designed for collecting dry materials only.

What size tool ports will this work with?

The Supercell and Supercell Turbo are designed for use with tools that have dust collection ports between 1" and 5" in diameter. We do not recommend the Supercell to Supercell Turbo to be used with ports larger than 5" in diameter.

How many tools can I collect from simultaneously?

The Supercell and Supercell Turbo can accommodate up to three 1" to 2.5" tools at the same time or one tool with a 4" or 5" diameter port.

What's the furthest length and diameter of hose that I can run?

You can run up to one hundred feet of four inch flex hose.

How flexible is the heavy-duty, hose and what is the minimum bend radius?

The vacuum rated 4" hose, used for the Supercell strikes a balance between flexibility and durability. Because of the Supercell's intense vacuum pressure, some lesser hoses can be problematic or even dangerous since they can "pull" (tighten up like an accordion bellows) when subjected to vacuum pressure. Our vacuum rated hose will prevent this while still allowing the hose to flex. The hose can be bent into a tight radius, around 1-1.25X CLR of the diameter. So for 4" hose, one can achieve a centerline radius of around 4-5". See images. That said, this hose has a strong memory and is wire reinforced. It WILL NOT lie in place when aggressively bent and will try to spring back to a more linear shape if not held in place.

Can I connect Flex Hose directly to the inlet?

Yes, it will be a secure and firm fit. However, you can secure it further by using a Quick-Release Hose Clamp (ACB640000). Each clamp can easily adjust in size to slip over the hose and can then be tightened using the convenient turn key handle.

I'm having trouble attaching flex hose to the inlet, do you have any tricks?

Start with the cut end of the hose and pull the hose ends up little by little to work the hose onto the cyclone's discharge. Pliers can be used to grab the reinforcing wire and aid in pulling the hose over the opening.

Is it normal for the motor housing (black cowling) to feel hot during operation?

Yes this is typical. All fan motors generate heat, which is why it's important to leave 1-2" of clearance around the motor's vent for proper circulation.

Where do I mount the included Dust Sentry?

The strobe can be mounted anywhere convenient that is within reach of the wiring.

F.A.Q. (Continued)

What duct layout works with the Supercell?

The Supercell isn't a traditional dust collector and operates at such a high-pressure (97.8" WC), any pressure loss from ductwork will have a negligible impact on the overall performance of the system. In other words, the Supercell simplifies ducting considerations because the ductwork guidelines for traditional dust collectors no longer apply.

	HIGH-PRESSURE SYSTEMS (SUPERCCELL)	LOW-PRESSURE SYSTEMS (MINI-GORILLA, V-SYSTEM, ETC.)
Main Line	Use 4" pipe or hose all the way to the tool.	Start as large as possible (up to the size of the collector's inlet) and reduce at branches if needed.
Branches	Use any kind of joint, including Tee-Joints, for your ductwork branches.	Only use 45 degree Wye joints to form new branches. Reduce splitting as much as possible.
Turns	Use any radius of elbow, including short radius turns.	Use large radius, 90 degree turns or two 45 degree elbows coupled together
Total Length	Run ducting wherever convenient: Perimeter layouts are perfectly fine.	Run ducting to tools in most direct path; Minimize overall length.
Drops	Either connect small hose directly to the main line (at a Tee joint for example) or run 4" right to the tool with a reducer at the end.	Gradually reduce in size from the main line to the tool inlet.
Duct Type	Should only use high-pressure rated components, such as Quick-Clamp ducting and vacuum rated hose.*	Varies, but typically 24-26 gauge ducting is acceptable along with wire-reinforced flex hose.

Why is there a blast gate at the inlet?

The blast gate at the inlet simplifies pulse cleaning of the filter.

What hose and ductwork is compatible with the Supercell?

Only use vacuum pressure rated flex-hose and duct with the Supercell dust collector. Under the system's high suction, standard hose/pipe may collapse causing affixed tools to be pulled towards the system, potentially causing damage and/or injury.

Oneida Air Systems recommends sheet metal ductwork that is 24 gauge or thicker, preferably spiral reinforced or clamp-together style ducting. Any hose used with the Supercell system should specifically state that it is rated for high vacuum pressure. Hose should be wire reinforced and have a rigid structure that undergoes minimal compression under negative vacuum pressures greater than 60" WC.

Is your Quick-Clamp Duct compatible with Nordfab Quick-Fit Ducting?

Yes! As long as the opening pipe diameters are the same, OAS Quick-Clamp Duct components can be combined and used interchangeably with Nordfab® QF ducting and other common clamp-together ductwork products.

F.A.Q. (Continued)

Do you have a ductwork kit that includes everything I need to get started?

Yes, we have two different ductwork kits to help with your setup. The Supercell Quick-Start Ductwork Kit (KDZ000012) and the 4" Supercell Ductwork Starter Kit (DBK040000). Both Ductwork Starter Kits are specifically designed for use with the Supercell High-Pressure Dust Collector product line. It is not intended for use with traditional low-pressure dust collectors. The Supercell's high-pressure, universal design can accommodate nearly any type of layout - even one formed entirely of flex hose!

The Supercell Quick-Start Ductwork Kit (KDZ000012) includes:

- a. One 4" × 2.5' Flex Hose
- b. Four 4" × 5' Straight Pipes (GPZ040000)
- c. Two 4" Duct Sleeves (GNZ040000)
- d. Thirteen 4" Quick-Clamps (GCZ040000)
- e. Six 4" Ductwork Wall Hangers (DBH040001)
- f. One 4" 90° SR Elbow (GES049000)
- g. Four 4 × 4 × 4" Gated Tee-Joint Kits (DMT040404)
- h. One 4" Blast Gate (GGZ040000)
- i. Two 4" Hose Adapters (GAF040000)
- j. One 4" × 2.5' Flex Hose
- k. Six 4" Turn-Key Hose Clamps (ACB640000)
- l. Cleanshop Accessory Kit (ASK000000)

The 4" Supercell Ductwork Starter Kit (DBK040000) includes:

- a. One 4" × 25' High-Pressure Flex Hose (DHF042502)
- b. Two 4 × 4 × 4" Crimped 45° Wye Joints (DBW040404)
- c. Three 4" Blast Gates (DGA040000)
- d. Three 4" Male Duct Adapters (DAF040000)
- e. Three 4" Female Duct Adapters (DAB040000)
- f. Ten 4" Turn-Key Hose Clamps (ACB640000)
- g. Cleanshop Accessory Kit (ASK000000)

How often can I start/stop the Supercell?

Frequent starts & stops are less of a concern with the Supercell system compared to larger dust collectors but it's still recommended to keep it to a minimum whenever possible to prolong the lifespan of the motor. The occasional power cycling is fine (i.e. a few times per hour) but we do not recommend integrating the Supercell with an automatic switch that may turn the system on and off every few minutes.

I have saw dust in the hold down tube for my system, what causes this?

This will occur if there is a tear within the bag or the system is not properly sealed, If you are not using a bag within the drum, please make sure to check that the valve is closed or the plug depending on the year of the system.

I hear a loud bang/pop from the dust drum (30, 35, or 55 gallon drum) when I turn the system on, is this normal?

Yes this sound is completely normal and in fact it's a sign of a good, airtight seal and a strong suction force!

When the drum is empty, the flat metal surface on the top and bottom of the bin may flex a bit as the system powers on and creates a negative air pressure zone within the drum. This flexing is what creates that loud bang or popping noise. In some cases the suction force can be so strong that the dust bin connection hose may constrict and pull the drum slightly off of the ground, which can also create a noise when the system powers off and the drum touches the ground again.

In both instances, this will only happen with an empty container and the noise will go away as the bin is filled and the system is more frequently used.

Troubleshooting

PROBLEM	CAUSE	SOLUTION
Motor Overheating/System Tripping (The motor's overload will trip if the motor is overheating)	Motor not properly wired	<ol style="list-style-type: none"> 1. Check wire connections. 2. Check breaker box to make sure power supply is correct for motor. 3. Check overload setting in starter.
Poor dust pick-up at Tools	System and ductwork connections	<ol style="list-style-type: none"> 1. Check length of duct runs, duct diameters, and hood design compared to ductwork design guidance. 2. Make sure all connections to the system are sealed. Large air losses will occur even through small cracks in the flex hose or ductwork. Use silicone, duct tape or duct mastic compound as a sealant. 3. Make sure everything is connected. 4. Check for air leaks between collector and dust drum. 5. Be sure that your filter is clean.
	One of the three motors may have reached its end of life	<ol style="list-style-type: none"> 1. Replacements can be found in the Recommended Accessories section. 2. Use the QR Code shown to download our instructions for the Testing and Replacement of the Motor Maintenance Kit. <div style="text-align: center;">  <p>SCAN ME</p> </div>
	Clogged Filter	<ol style="list-style-type: none"> 1. Pulse filter more frequently. 2. If air flow is not restored after pulsing remove and fully clean the filter. Review Cleaning the Filter section.



If you continue to experience difficulty with your dust collector, call Oneida Air Systems' Customer Service Department at 1-866-387-8822 or email support@oneida-air.com.

Troubleshooting (Continued)

PROBLEM	CAUSE	SOLUTION
Filter Clogging	Large chips clogging the filter	<ol style="list-style-type: none"> 1. Check for a leak in the dust bin or lid. 2. Make sure dust bin has not overfilled. Dust bin should be emptied before the dust reaches top of container.
	Fine dust clogging the filter	<ol style="list-style-type: none"> 1. Heavy sanding with a drum sander or fine grit paper will cause the pleated filter media to bind sooner than with larger size dust. Pulse filter more frequently.
System Lost Suction	One of the three motors may have reached its end of life	<ol style="list-style-type: none"> 1. Replacements can be found in the Recommended Accessories section. 2. Use the QR Code shown to download our instructions for the Testing and Replacement of the Motor Maintenance Kit. <div style="text-align: center;">  <p>SCAN ME</p> </div>
Remote control won't turn off the system	Electrical interference from the motor is interrupting the remote's frequency	<ol style="list-style-type: none"> 1. Power off and unplug the system. 2. Find the Antenna Extension Wire (A1) can be further extended for improved reception if still necessary. Use wire strippers to expose metal on the wire and attach an additional length.



If you continue to experience difficulty with your dust collector, call Oneida Air Systems' Customer Service Department at 1-866-387-8822 or email support@oneida-air.com.

Recommended Accessories



13" x 13" Conical HEPA Cartridge Filter

#FCS131040H

- Independently tested G.E. Certified H12 HEPA filter media.
- Wide-spaced pleated filters with non-stick coating for quick and easy dust removal.
- Unique conical shape greatly facilitates dust release during pulse cleaning



5X Small 1.5 Mil Plastic Liner Bags

#AXD600300A

- Lines the inside of medium sized, 9-17 gallon containers for fast and simple waste disposal.
- Heavy thickness protects against tearing from wood chips or other sharp debris.
- 16 x 14 x 36"



Supercell / Supercell Turbo Motor Set Replacement

#BMX311230 / #BMX411230

- The motors install quickly and easily onto the system with minimal tools required.
- Includes motors, spacers, and gasket.
- All motors should be replaced at the same time.



Supercell 4" / 2.5" Quick-Clamp Ductwork Kit

#KDZ000012

- Upgrade your Supercell dust collector to connect to multiple tools simultaneously.
- Includes gated connection ports for two 4" diameter and three 2.5" diameter connections.
- Features modular quick-clamp duct fittings that are highly customizable for any shop.



CleanShop 2.5" x 25' Vacuum Hose Accessory Kit

#ASK000000

- Turn your dust collector into vacuum system with this complete hose accessory kit.
- Crush-resistant hose features smooth inner wall for minimal air resistance.
- Includes common vacuum head accessories including crevice tool, floor tool, and more!

Recommended Accessories (Continued)



4" Supercell Ductwork Starter Kit

#DBK040000

- Upgrade your Supercell dust collector to connect to multiple tools simultaneously.
- Includes 3x manual blast gates for flexible tool connections throughout the shop.
- Combine this kit's high-pressure rated hose with the Supercell's own included hose for up to 50 feet of length.



4" x 25' Vacuum Pressure Rated Flex-Hose

#DHF042502

- Heavy-duty, abrasion resistant flex hose designed for use with high-pressure systems.
- Constructed from thick polyurethane and reinforced with a wire helix.
- Perfect when using a single connection to switch between multiple tools.



4" - 2.5" Reducer

#DRL040212

- Useful for reducing the diameter of the ductwork connecting to your tools and/or flex hose.
- Tapered for high airflow efficiency.
- Heavy wall thickness.



Replacement Key Fob

#AMR000000

- Sends long range wireless signal via radio frequency that works at long distances and even through walls!
- Purchase of this item includes the Key Fob ONLY.



Universal Drum Dolly

#SDD990000

- This lightweight and low profile mobile dolly fits nearly any cylindrical waste bin.
- Includes hardware for securing larger drums to the dolly.
- Includes five 2" non-marking caster wheels (3 non-locking, 2 locking).

Warranty Information

Limited Warranty – Activate online at oneida-air.com/warranty

Oneida Air Systems®, Inc. (OAS) warrants the Supercell for a period of 1 year, to the original purchaser from the date of purchase, unless otherwise specified. Items not manufactured by Oneida Air Systems are limited to their own manufacturer's warranties. All electrical items such as magnetic starters, remotes, sensors, pumps, bin sensors, bag grippers, etc. and accessories are limited to 90 days. Oneida Air Systems warrants that the product will be free from defects in materials and workmanship.

This is Oneida Air Systems' sole written warranty and any and all warranties that may be implied by law, including any merchantability or fitness, for any particular purpose, are hereby limited to the duration of this written warranty. Oneida Air Systems does not warrant or represent that the merchandise complies with the provisions of any law or acts unless the manufacturer so warrants. This warranty does not apply to defects due directly or indirectly to misuse, negligence, accidents, abuse, repairs, alterations, improper wiring or lack of maintenance. In no event shall Oneida Air Systems' liability under this warranty exceed the purchase price paid for the product and any legal actions brought against Oneida Air Systems shall be tried in the State of New York, County of Onondaga.

The buyer is cautioned to install and operate Dust Collectors in accordance with prescribed Federal, State, OSHA, NFPA, local codes and regulations. This equipment should be installed/wired by a licensed electrician following all applicable codes. Local codes can be significantly different from national codes. The customer assumes the responsibility for contacting their insurance underwriter with regard to specific application requirements of venting or if additional fire protection and safety equipment may be required. Oneida Air Systems shall in no event be liable for death, injuries to persons or property or for incidental, and contingent, special, or consequential damages arising from the use of our product.

Oneida Air Systems makes every effort to accurately represent our products and prices, however Oneida Air Systems reserves the right to make changes to products and prices at any time. As a manufacturer, Oneida Air Systems reserves the right to change product specifications at any time in an effort to achieve better quality products.



ONEIDA AIR SYSTEMS SHALL IN NO EVENT BE LIABLE FOR DEATH, INJURIES TO PERSONS OR PROPERTY, OR FOR INCIDENTAL AND CONTINGENT, SPECIAL, OR CONSEQUENTIAL DAMAGES ARISING FROM THE USE OF OUR PRODUCT.

SAFETY WARNING - PLEASE READ

Before Purchasing or Installing a dust collection system the buyer is cautioned to do so in accordance with prescribed Federal, State, Local, OSHA, NFPA, and any other applicable codes or regulations relating to the type of dust(s) you are collecting.

SOME TYPES OF DUST UNDER CERTAIN CONDITIONS HAVE THE POTENTIAL TO BE EXPLOSIVE.

Oneida Air Systems is not responsible for how the dust collector is used or installed. Dusts with deflagration or explosion risks, such as wood dust, may require additional safety equipment including but not limited to; venting, spark detection, suppression systems, back draft dampers or may require installation in an outside location or in a protected area away from personnel. The customer assumes the responsibility for contacting their insurance underwriter with regard to specific engineering controls or application requirements. (We suggest you reference NFPA 664, 654 and 68 codes for more information) Oneida Air Dust Collection Systems may not be suitable for some applications and are not designed to be used in explosive atmospheres. Oneida Air Systems equipment should only be installed and wired by a licensed electrician following all applicable local and national electrical codes.

Some dust created by power sanding, sawing, grinding, drilling, and other construction activities contains chemicals known to cause cancer, birth defects or other reproductive harm. Some examples of these chemicals are: Lead from lead-based paints; Crystalline silica from bricks, cement and other masonry products; Arsenic and chromium from chemically-treated lumber; etc.

Your risk from these exposures varies, depending on how often you do this type of work. To reduce your exposure to these chemicals, work in a well ventilated area, and work with approved safety equipment, such as those dust masks that are specially designed to filter out microscopic particles. Oneida Air Systems recommends using additional approved safety equipment such as an approved OSHA and NIOSH dust mask or respirator.

Oneida Air Systems makes every effort to accurately represent our products, specifications and prices; however Oneida Air Systems reserves the right to make changes to products and prices at any time. As a manufacturer, Oneida Air Systems reserves the right to change product designs and specifications at any time.



The **Industry Leader in Dust Collection**

Thank you for your business!

Regardless of where you purchased your system, if you have any questions or issues with missing / damaged parts, please call Oneida Air Systems first to let us help resolve your problem. We fully stand behind the quality of our product and place the utmost value satisfaction of our customers.

We want to do everything possible to make your purchase and experience with Oneida Air Systems a good one!

Customer Service Dept.

1-866-387-8822 • support@oneida-air.com

1001 West Fayette Street, Syracuse, NY 13204 U.S.A.

Copyright © 2024 Oneida Air Systems, Inc.